

Feature

- This device is Pb-Free, Halogen Free/BFR Free and Rohs compliant.

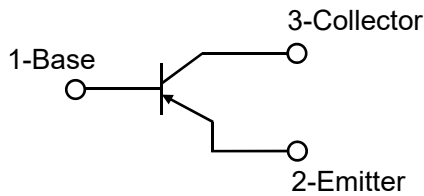

Circuit Diagram

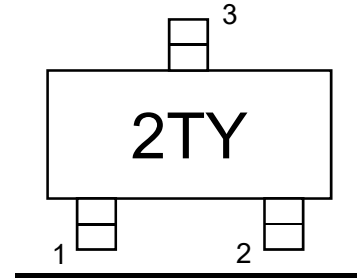

Marking (Top View)

Mechanical Characteristics

- Lead finish:100% matte Sn(Tin)
- SOT-23 without plating
- Mounting position: Any
- Qualified max reflow temperature:260°C
- Device meets MSL 1 requirements
- Pure tin plating: 7 ~ 17 um
- Pin flatness:≤3mil

Electrical characteristics per line@25°C

Parameter	Symbol	Conditions	Min.	Typ.	Max.	Units
Collector-base breakdown voltage	$V_{(BR)CBO}$	$I_C = -100\mu A, I_E = 0$	-40	-	-	V
Collector-emitter breakdown voltage	$V_{(BR)CEO}$	$I_C = -1mA, I_B = 0$	-25	-	-	V
Emitter-base breakdown voltage	$V_{(BR)EBO}$	$I_E = -100\mu A, I_C = 0$	-5	-	-	V
Collector cut-off current	I_{CEO}	$V_{CE} = -20V, I_B = 0$	-	-	-100	nA
Collector cut-off current	I_{CBO}	$V_{CB} = -40V, I_E = 0$	-	-	-100	nA
Emitter cut-off current	I_{EBO}	$V_{EB} = -3V, I_C = 0$	-	-	-100	nA
DC current gain	$h_{FE(1)}$	$V_{CE} = -1V, I_C = -50mA$	120	-	400	
	$h_{FE(2)}$	$V_{CE} = -1V, I_C = -500mA$	50	-	-	
Collector-emitter saturation voltage	$V_{CE(sat)}$	$I_C = -500mA, I_B = -50mA$	-	-	-0.6	V
Base-emitter saturation voltage	$V_{BE(sat)}$	$I_C = -500mA, I_B = -50mA$	-	-	-1.2	V
Transition frequency	f_T	$V_{CE} = -6V, I_C = -20mA, f = 30MHz$	150	-	-	MHz

Absolute maximum rating@25°C

Parameter	Symbol	Value	Units
Collector-Base Voltage	V_{CBO}	-40	V
Collector-Emitter Voltage	V_{CEO}	-25	V
Emitter-Base Voltage	V_{EBO}	-5	V
Collector Current -Continuous	I_C	-500	mA
Collector Power Dissipation	P_C	300	mW
Thermal Resistance from Junction to Ambient	$R_{\theta JA}$	417	°C/W
Junction Temperature	T_J	150	°C
Storage Temperature	T_{STG}	-55 ~ +150	°C

Typical Characteristics

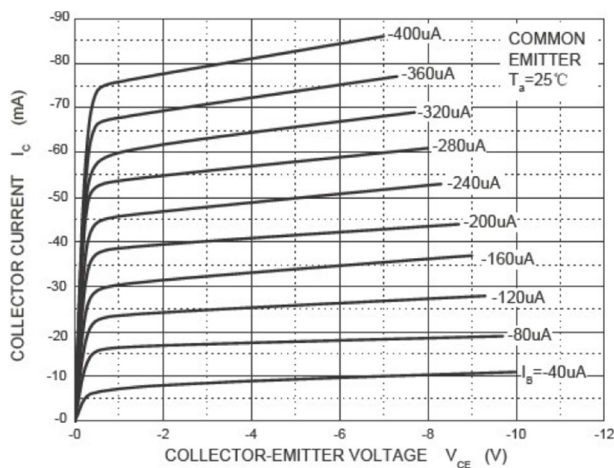

Fig 1 I_C — V_{CE}

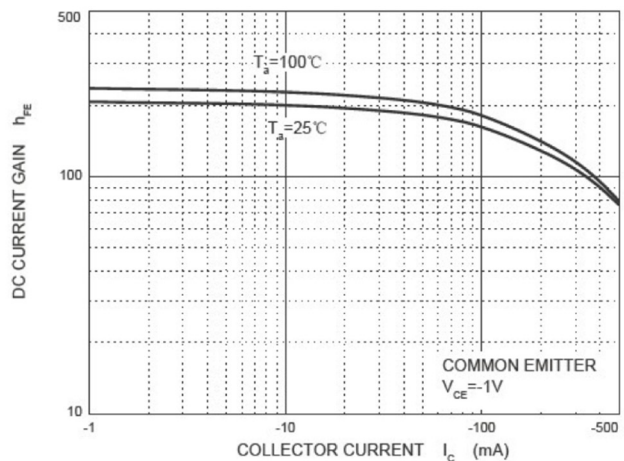

Fig 2 h_{FE} — I_C

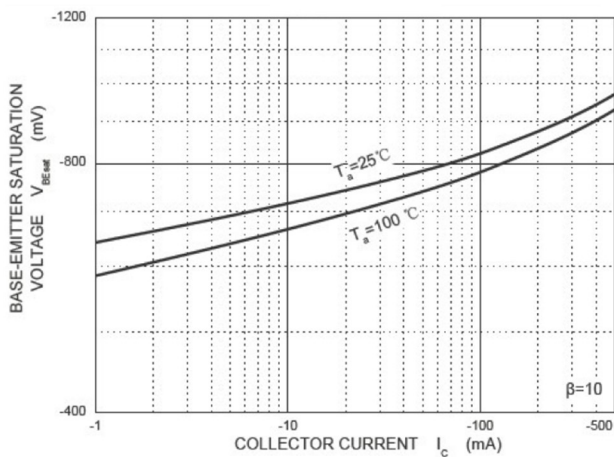

Fig 3 V_{BEsat} — I_C

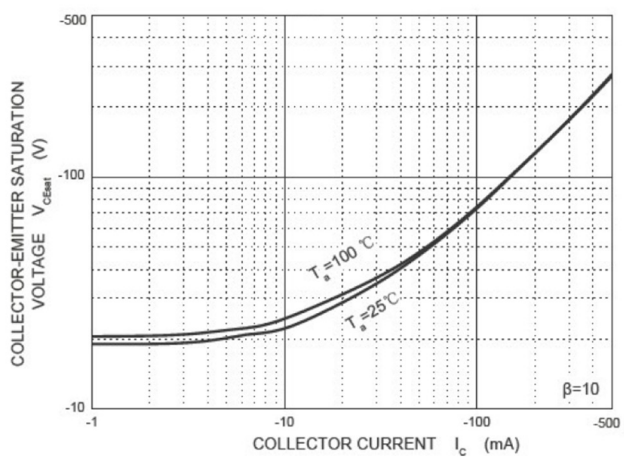

Fig 4 V_{CEsat} — I_C

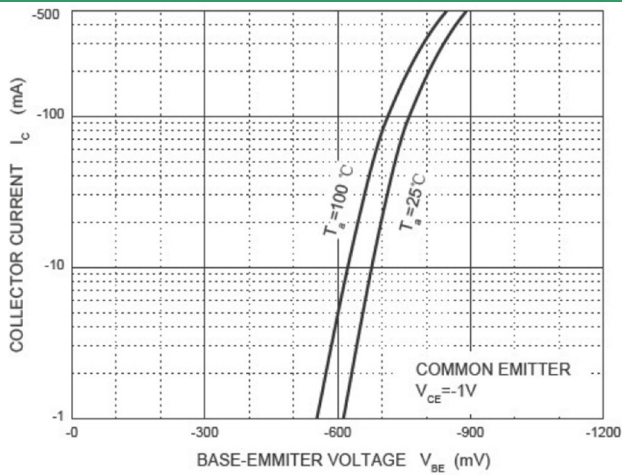

Fig 5 I_c — V_{BE}

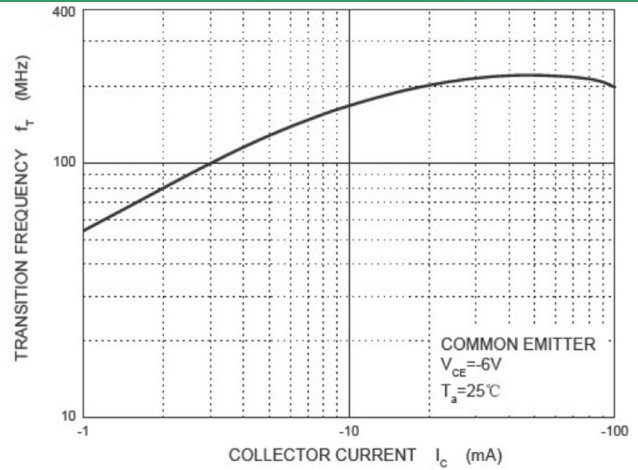

Fig 6 f_T — I_c

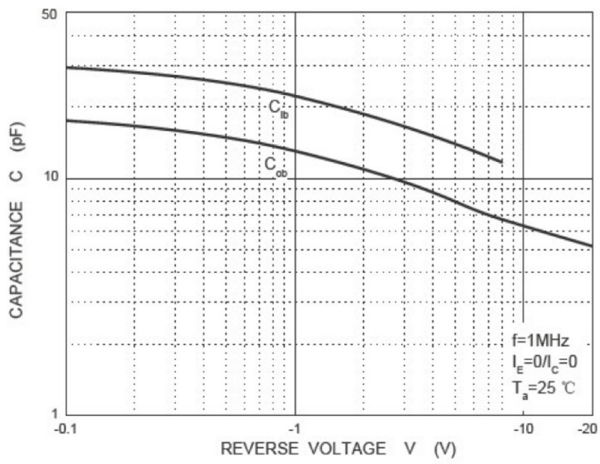

Fig 7 C_{ob}/C_{ib} — V_{CB}/V_{EB}

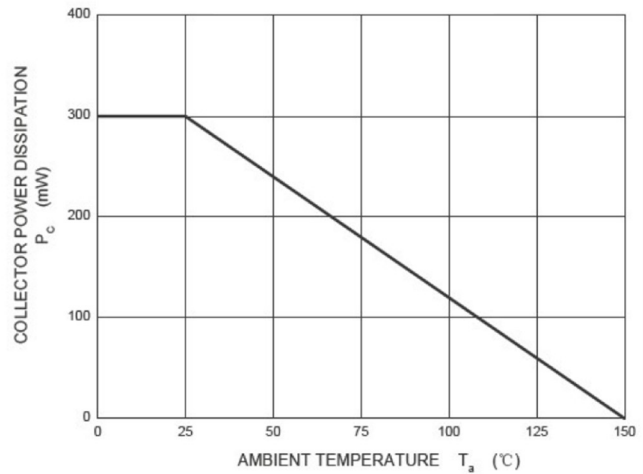
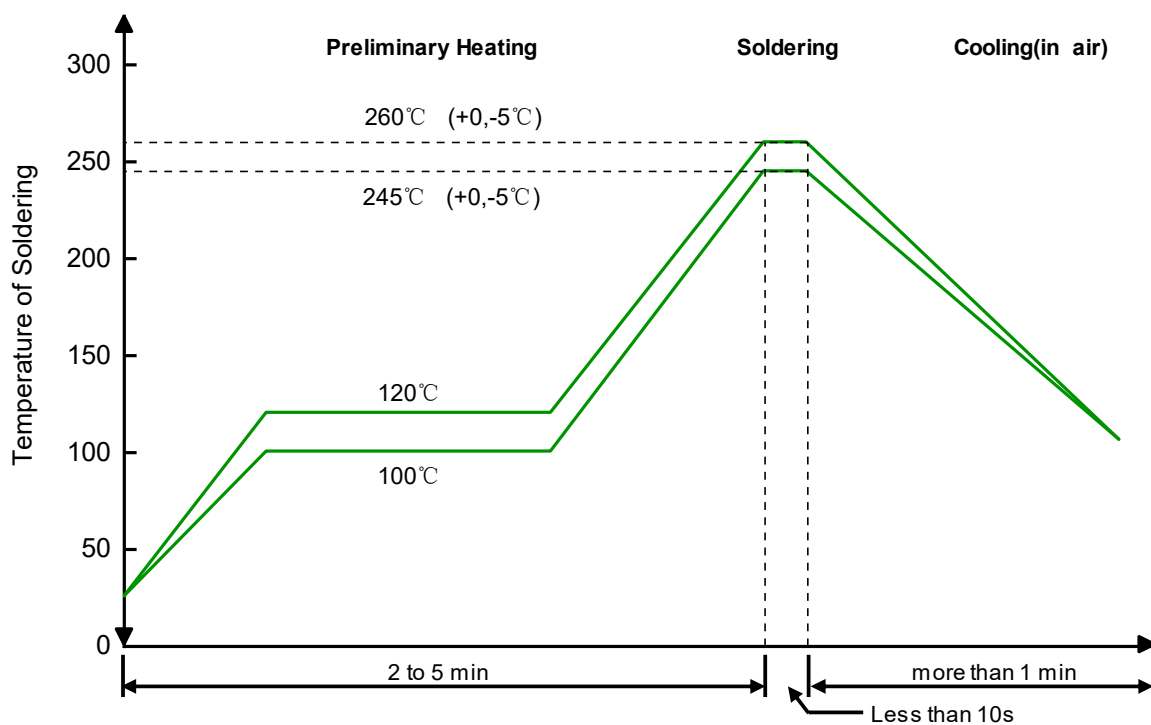

Fig 8 P_c — T_a

Solder Reflow Recommendation



Remark: Pb free for 260°C; Pb for 245°C.

Product dimension (SOT-23)

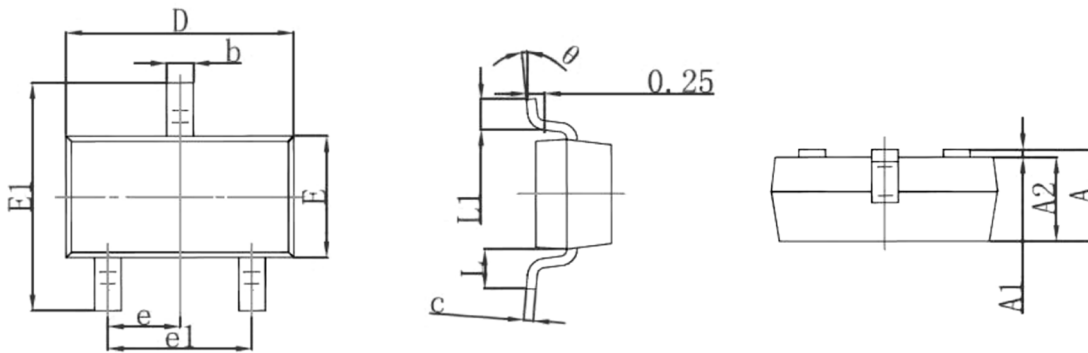

Dim	Millimeters		Inches	
	Min	Max	Min	Max
A	0.900	1.150	0.035	0.045
A1	0.000	0.100	0.000	0.004
A2	0.900	1.050	0.035	0.041
b	0.300	0.500	0.012	0.020
c	0.080	0.150	0.003	0.006
D	2.800	3.000	0.110	0.118
E	1.200	1.400	0.047	0.055
E1	2.250	2.550	0.089	0.100
e	0.950 Typ.		0.037 Typ.	
e1	1.800	2.000	0.071	0.079
L	0.550 Ref.		0.022 Ref.	
L1	0.300	0.500	0.012	0.020
θ	0°	8°	0°	8°

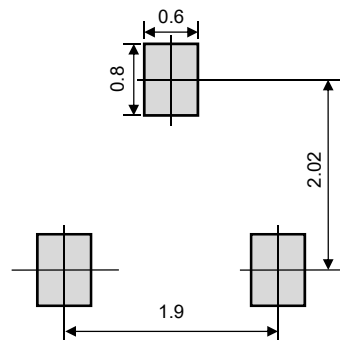

Unit:mm

Suggested PCB Layout

Ordering information

Device	Package	Reel	Shipping
PT23T8550L	SOT-23 (Pb-Free)	7"	3000 / Tape & Reel

IMPORTANT NOTICE

 and **Prisemi**[®] are registered trademarks of **Prisemi Electronics Co., Ltd** (Prisemi), Prisemi reserves the right to make changes without further notice to any products herein. Prisemi makes no warranty, representation or guarantee regarding the suitability of its products for any particular purpose, nor does Prisemi assume any liability arising out of the application or use of any product or circuit, and specifically disclaims any and all liability, including without limitation special, consequential or incidental damages. “Typical” parameters which may be provided in Prisemi data sheets and/or specifications can and do vary in different applications and actual performance may vary over time. All operating parameters, including “Typicals” must be validated for each customer application by customer’s technical experts. Prisemi does not convey any license under its patent rights nor the rights of others. The products listed in this document are designed to be used with ordinary electronic equipment or devices, Should you intend to use these products with equipment or devices which require an extremely high level of reliability and the malfunction of with would directly endanger human life (such as medical instruments, aerospace machinery, nuclear-reactor controllers, fuel controllers and other safety devices), please be sure to consult with our sales representative in advance.

Website: <http://www.prisemi.com>

For additional information, please contact your local Sales Representative.

©Copyright 2009, Prisemi Electronics

 **Prisemi**[®] is a registered trademark of Prisemi Electronics.

All rights are reserved.