

Feature

- NPN epitaxial planar silicon transistor
- Power Dissipation of 300mW
- High Stability and high reliability

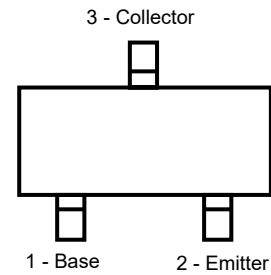

Top View

Mechanical Characteristics

- Mounting position: Any
- Qualified max reflow temperature: 260°C
- Device meets MSL 1 requirements
- SOT-23 Small Outline Plastic Package

Absolute maximum rating@25°C

Parameter	Symbol	Value	Units
Collector-Base Voltage	V_{CBO}	180	V
Collector-Emitter Voltage	V_{CEO}	160	V
Emitter -Base Voltage	V_{EBO}	6	V
Collector Current - Continuous	I_C	600	mA
Collector Power Dissipation	P_C	300	mW
Thermal Resistance, Junction to Ambient	$R_{\theta JA}$	416	°C/W
Junction Temperature	T_J	150	°C
Storage Temperature	T_{STG}	-55 to +150	°C

Electrical characteristics per line@25°C (unless otherwise specified)

Parameter	Symbol	Conditions	Min.	Typ.	Max.	Unit
Collector-Base Breakdown Voltage	$V_{(BR)CBO}$	$I_C=100\mu A, I_E=0$	180	-	-	V
Collector-Emitter Breakdown Voltage	$V_{(BR)CEO}$	$I_C=1mA, I_B=0$	160	-	-	V
Emitter -Base Breakdown Voltage	$V_{(BR)EBO}$	$I_E=-10\mu A, I_C=0$	6	-	-	V
Collector Cutoff Current	I_{CBO}	$V_{CB}=120V, I_E=0V$	-	-	50	nA
Emitter Cutoff Current	I_{EBO}	$V_{EB}=4V, I_C=0$	-	-	50	nA
DC Current Gain	H_{FE}	$I_C=1.0mA, V_{CE}=5.0V$	80	-	-	-
		$I_C=10mA, V_{CE}=5.0V$	100	-	300	
		$I_C=50mA, V_{CE}=5.0V$	30	-	-	
Collector-Emitter Saturation Voltage	$V_{CE(sat)}$	$I_C=10mA, I_B=1.0mA$	-	-	0.15	V
		$I_C=50mA, I_B=5.0mA$	-	-	0.20	
Base-Emitter Saturation Voltage	$V_{BE(sat)}$	$I_C=10mA, I_B=1.0mA$	-	-	1.0	V
		$I_C=50mA, I_B=5.0mA$	-	-	1.0	
Transition frequency	f_T	$I_C=10mA, V_{CE}=10V,$ $f=100MHz$	100	-	300	MHz
Collector Output Capaciatnce	C_{ob}	$V_{CB}=120V, I_E=0V,$ $f=100MHz$			6	pF

Typical Characteristics

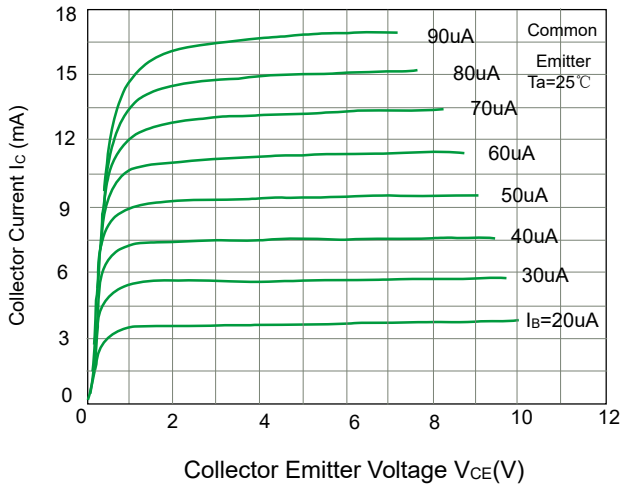

Fig 1. Static Characteristic

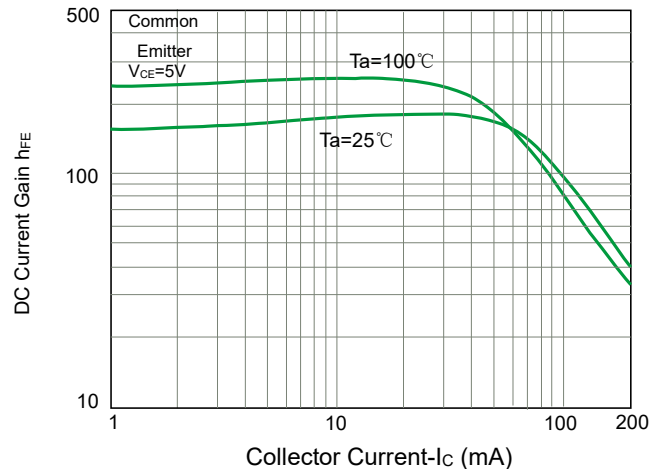

Fig2. h_{FE} ---- I_c

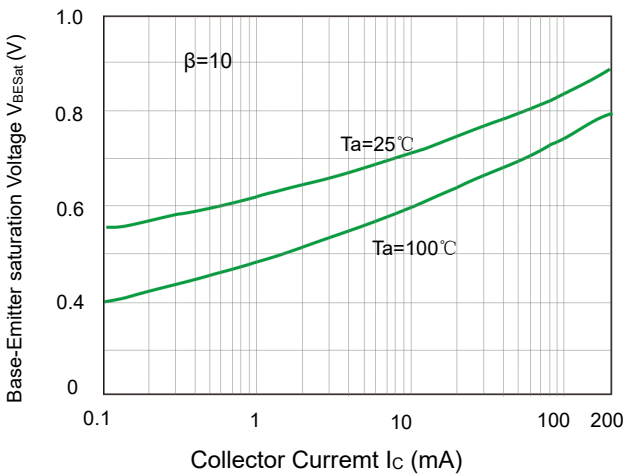

Fig 3. V_{BEsat} ---- I_c

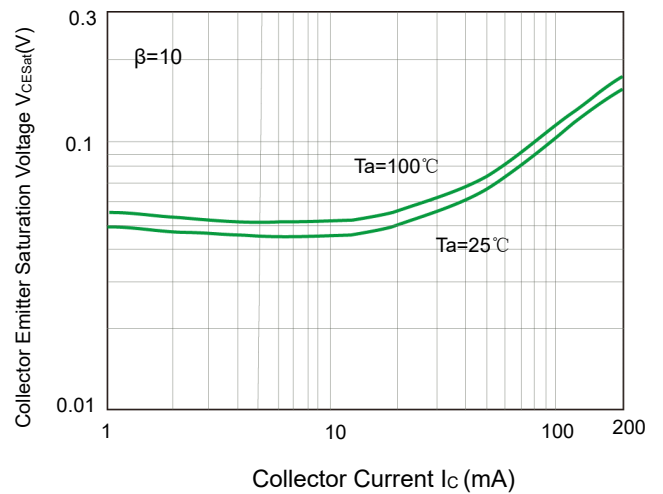

Fig4. V_{CEsat} ---- I_c

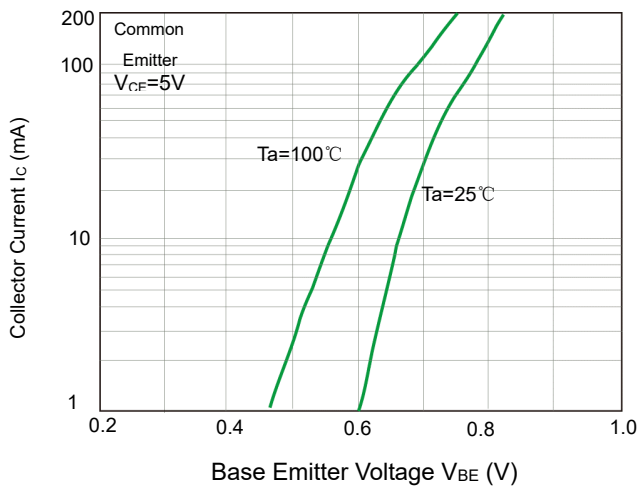

Fig 5. V_{BE} ---- I_c

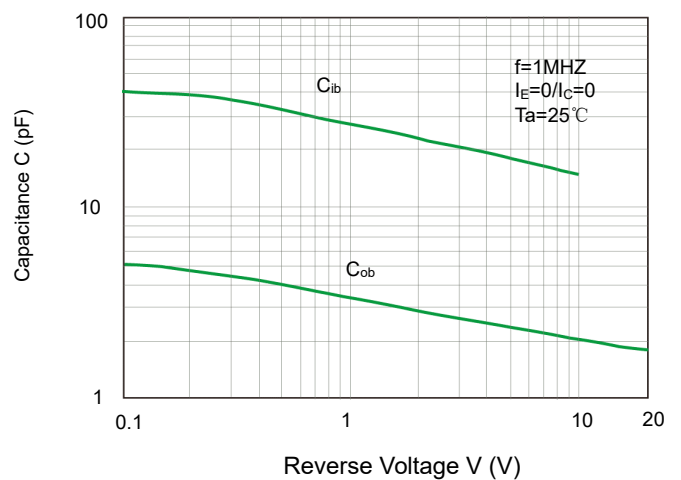

Fig 6. C_{ob}/C_{ib} ---- V_{CB}/V_{EB}

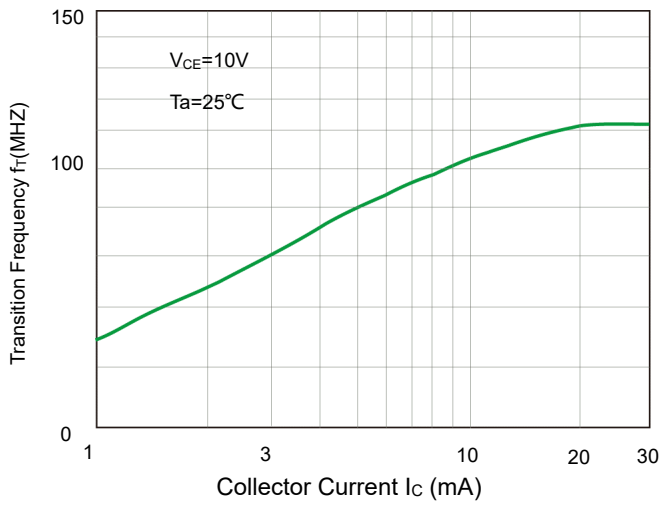

Fig 7. f_T ---- I_C

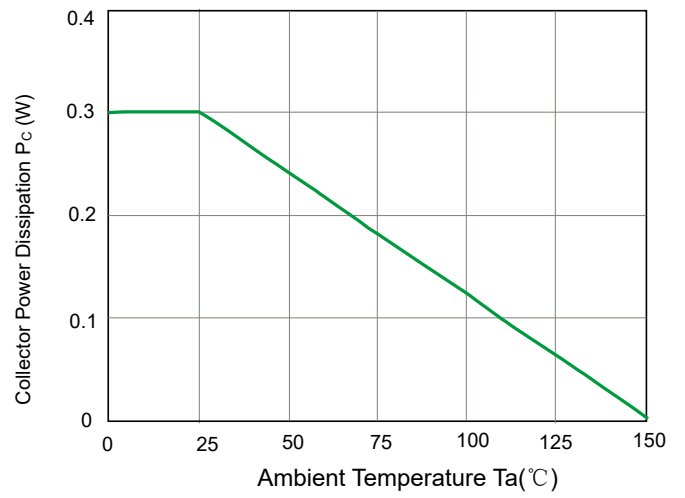
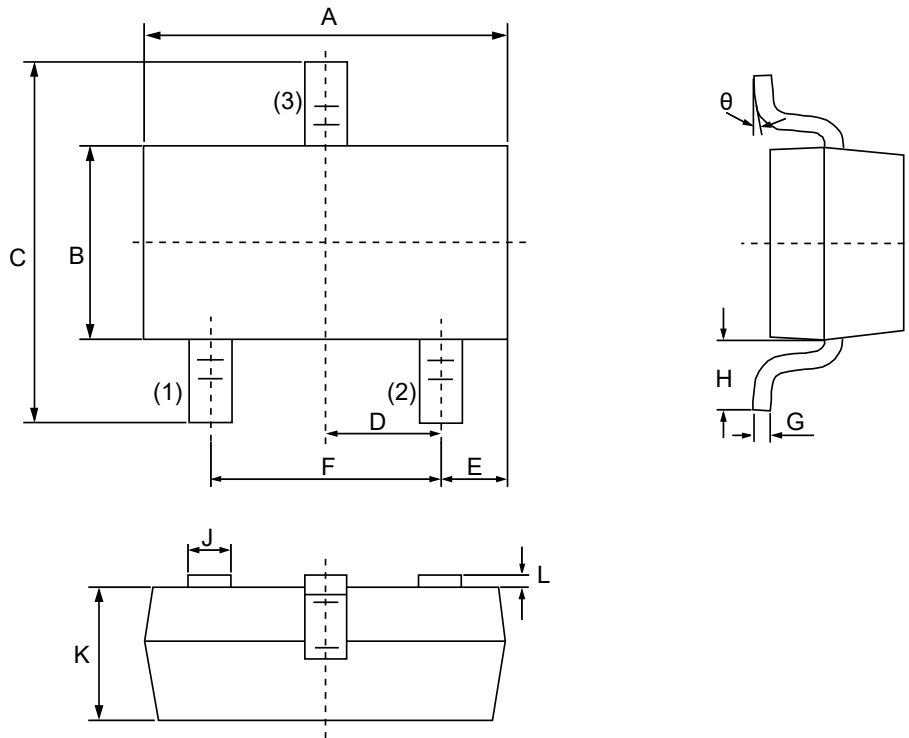
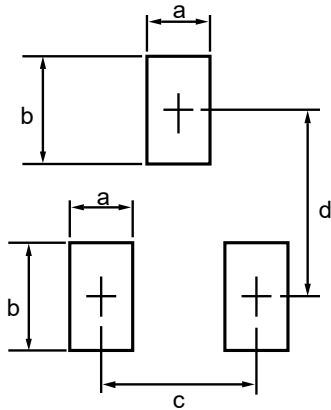

Fig8. P_C ---- T_a

Product dimension(SOT-23)



Dim	Millimeters		Inches	
	MIN	MAX	MIN	MAX
A	2.80	3.00	0.1102	0.1197
B	1.20	1.40	0.0472	0.0551
C	2.10	2.50	0.0830	0.0984
D	0.89	1.02	0.0350	0.0401
E	0.45	0.60	0.0177	0.0236
F	1.78	2.04	0.0701	0.0807
G	0.085	0.177	0.0034	0.0070
H	0.45	0.60	0.0180	0.0236
J	0.37	0.50	0.0150	0.0200
K	0.89	1.11	0.0350	0.0440
L	0.013	0.100	0.0005	0.0040
θ	0°	10°	0°	10°



Dim	Millimeters	
	MIN	MAX
a	--	0.7
b	--	1.2
c	--	2.04
d	--	2.2

Marking information

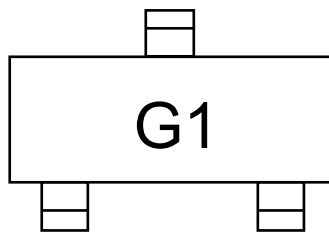

Ordering information

Device	Package	Reel	MPQ
PT23T5551	SOT-23 (Pb-Free)	7"	3000 / Tape & Reel

Load with information

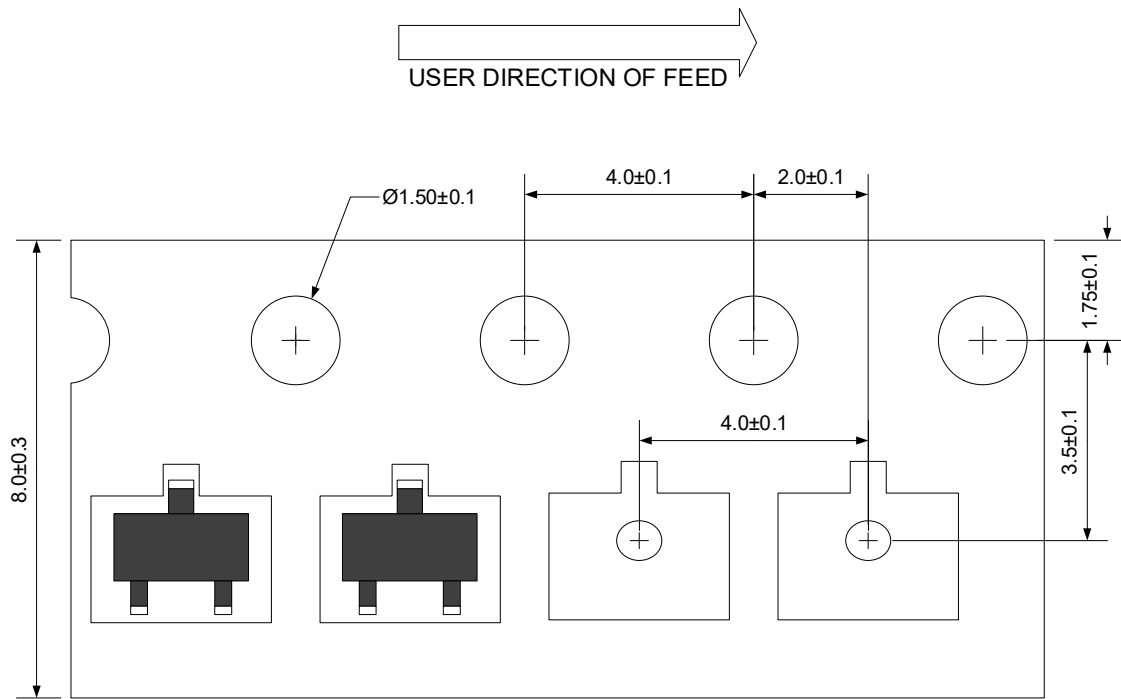

Unit:mm

IMPORTANT NOTICE

 and **Prisemi**[®] are registered trademarks of **Prisemi Electronics Co., Ltd** (Prisemi). Prisemi reserves the right to make changes without further notice to any products herein. Prisemi makes no warranty, representation or guarantee regarding the suitability of its products for any particular purpose, nor does Prisemi assume any liability arising out of the application or use of any product or circuit, and specifically disclaims any and all liability, including without limitation special, consequential or incidental damages. "Typical" parameters which may be provided in Prisemi data sheets and/or specifications can and do vary in different applications and actual performance may vary over time. All operating parameters, including "Typicals" must be validated for each customer application by customer's technical experts. Prisemi does not convey any license under its patent rights nor the rights of others. The products listed in this document are designed to be used with ordinary electronic equipment or devices, Should you intend to use these products with equipment or devices which require an extremely high level of reliability and the malfunction of with would directly endanger human life (such as medical instruments, aerospace machinery, nuclear-reactor controllers, fuel controllers and other safety devices), please be sure to consult with our sales representative in advance.

Website: <http://www.prisemi.com>

For additional information, please contact your local Sales Representative.

©Copyright 2009, Prisemi Electronics



is a registered trademark of Prisemi Electronics.

All rights are reserved.