

Feature

This device is Pb-Free, Halogen Free/BFR Free and RoHS compliant.

- Package: SOT-723
- Emitter -Base Breakdown Voltage 11V
- Low Saturation Voltage 80mv
- 0.15 continuous collector current
- NPN switch transistor

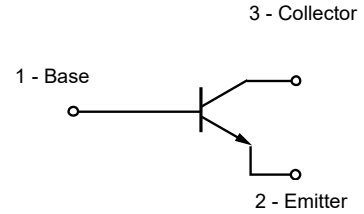

Circuit Diagram

Mechanical Characteristics

- Lead finish:100% matte Sn(Tin)
- Mounting position: Any
- Qualified max reflow temperature:260°C
- Device meets MSL 1 requirements
- Pure tin plating: 7 ~ 17 um
- Pin flatness : ≤3mil

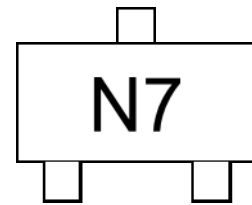

Marking (Top View)

Electrical characteristics per line@25°C (unless otherwise specified)

Parameter	Symbol	Value	Units
Collector-Emitter Breakdown Voltage	$V_{(BR)CEO}$	50	V
Collector-Base Breakdown Voltage	$V_{(BR)CBO}$	80	V
Emitter -Base Breakdown Voltage	$V_{(BR)EBO}$	11	V
Collector Current	I_C	0.15	A
Total Dissipation @25°C	P_{tot}	0.15	W
Storage Temperature	T_{stg}	-65~150	°C
Max. Operating Junction Temperature	T_j	150	°C

Absolute maximum rating@25°C

Parameter	Symbol	Conditions	Min.	Typ.	Max.	Units
Collector-Base Breakdown Voltage	BV_{CBO}	$I_C=50\mu A$	80			V
Collector-Emitter Breakdown Voltage	BV_{CEO}	$I_C=1mA$	50			V
Emitter-Base Breakdown Voltage	BV_{EBO}	$I_E=50\mu A$		11		V
Collector Cut-off Current ($I_E=0$)	I_{CBO}	$V_{CB}=60V$			0.1	μA
Emitter Cut-off Current ($I_C=0$)	I_{EBO}	$V_{EB}=7V$			0.1	μA
DC Current Gain	h_{FE}	$I_C=1mA, V_{CE}=6V$	200		350	-
Collector-Emitter Saturation Voltage	$V_{CE(sat)}$	$I_C=50mA, I_B=5mA$	-	0.08		V
Transition frequency	f_T	$V_{CE}=12V, I_E=-2mA, f=100MHz$		200		MHz
Output Capacitance	C_{ob}	$V_{CE}=12V, I_E=0mA, f=1MHz$		2	3.5	pF

Typical Characteristics

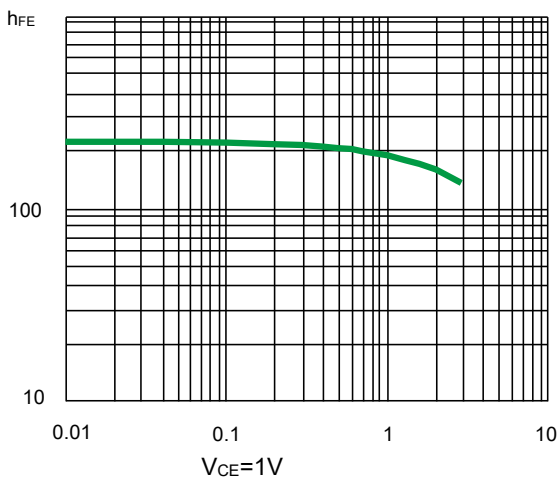

Fig1.DC Current Gain

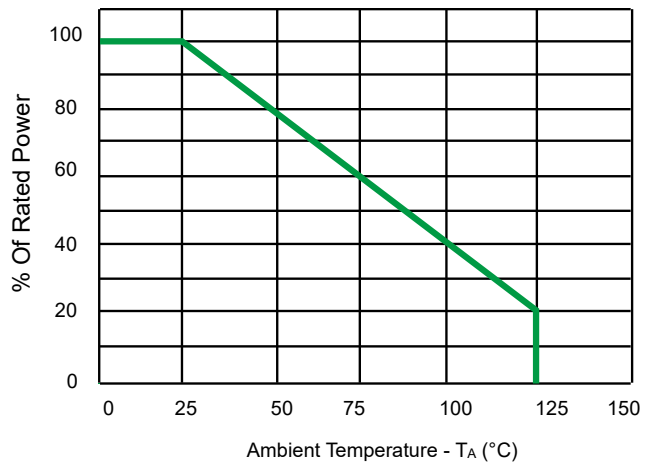

Fig2. Power Derating Curve

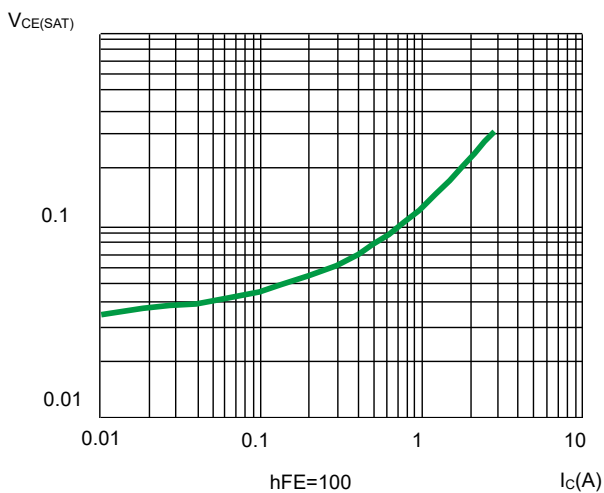

Fig 3.Collector-Emitter Saturation Voltage

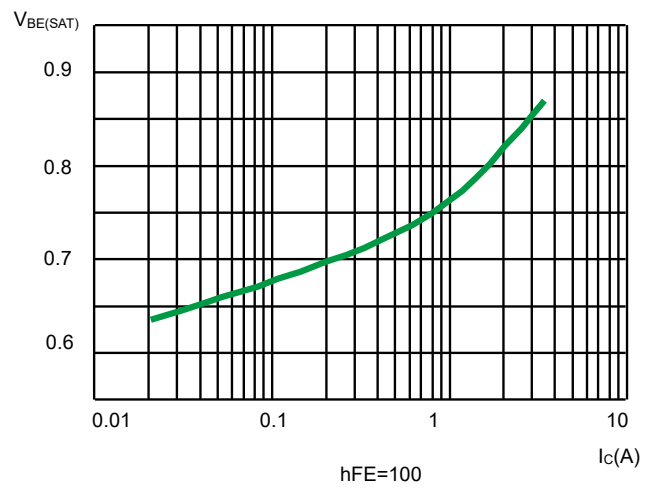

Fig4. Base-Emitter Saturation Voltage

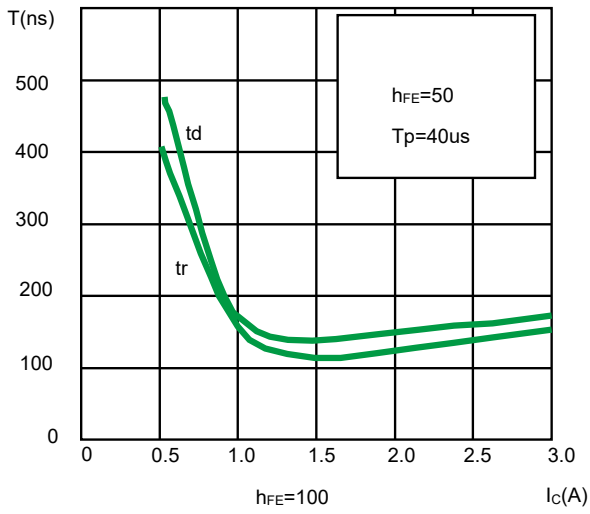

Fig 5. Switching Times Resistive Load

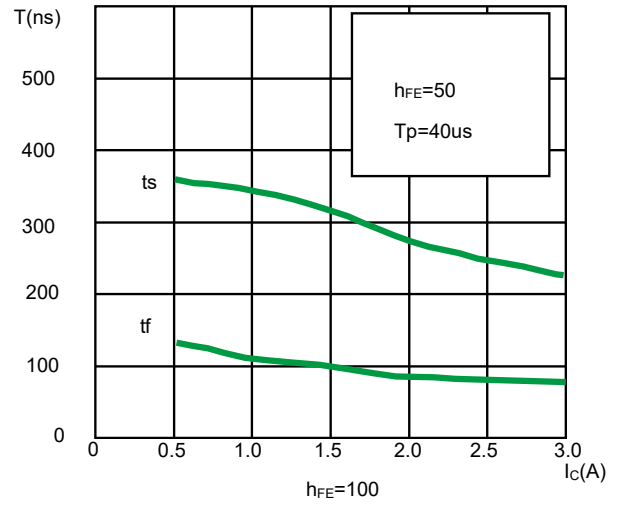
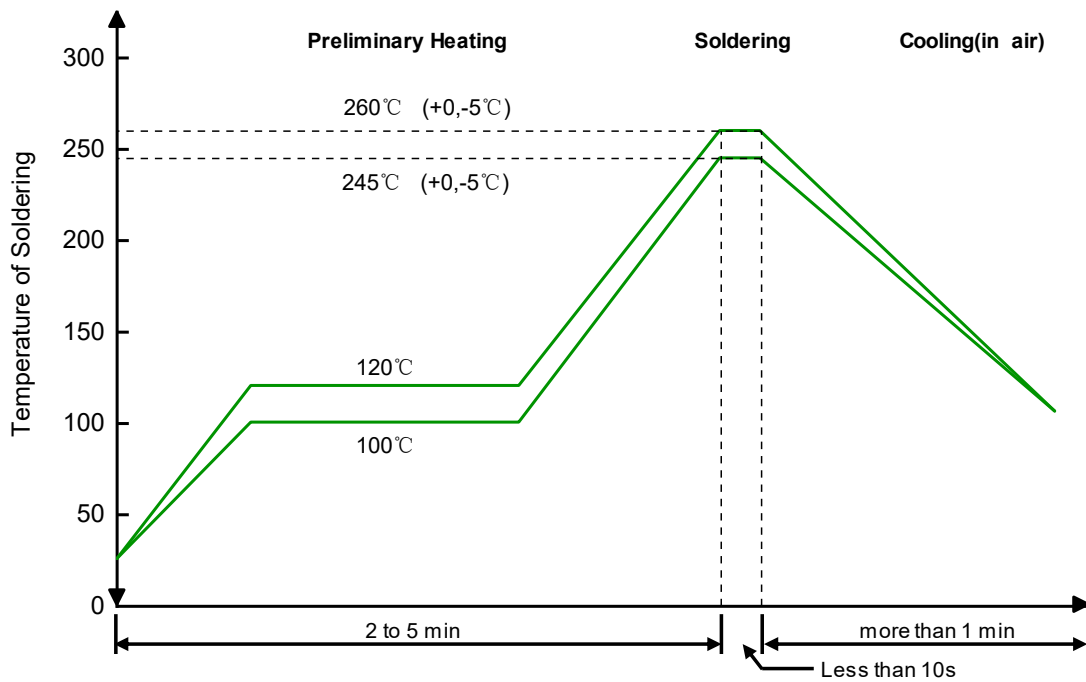

Fig6. Switching Times Resistive Load

Solder Reflow Recommendation



Remark: Pb free for 260°C; Pb for 245°C.

Product dimension (SOT-723)

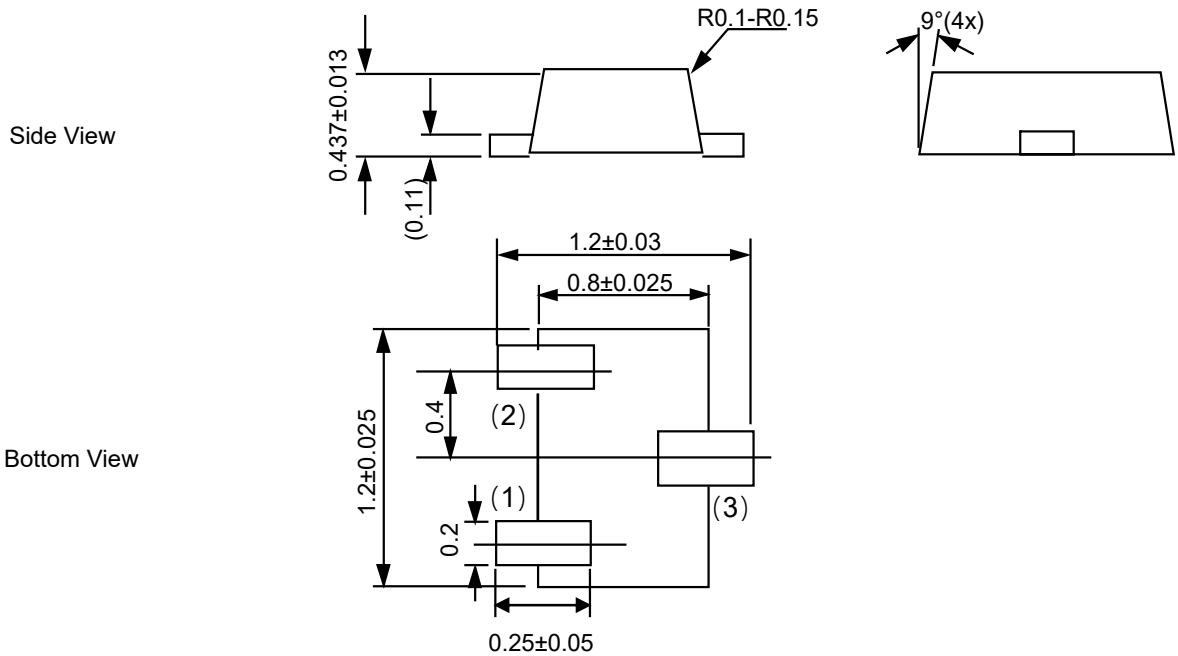

Unit: mm

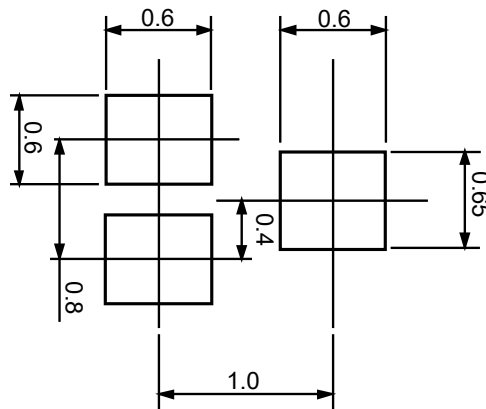

Unit: mm

Ordering information

Device	Package	Shipping
PNT723T503E0-2	SOT-723	10000 / Tape & Reel

IMPORTANT NOTICE

 and **Prisemi**[®] are registered trademarks of **Prisemi Electronics Co., Ltd (Prisemi)** ,Prisemi reserves the right to make changes without further notice to any products herein. Prisemi makes no warranty, representation or guarantee regarding the suitability of its products for any particular purpose, nor does Prisemi assume any liability arising out of the application or use of any product or circuit, and specifically disclaims any and all liability, including without limitation special, consequential or incidental damages. “Typical” parameters which may be provided in Prisemi data sheets and/or specifications can and do vary in different applications and actual performance may vary over time. All operating parameters, including “Typicals” must be validated for each customer application by customer’s technical experts. Prisemi does not convey any license under its patent rights nor the rights of others. The products listed in this document are designed to be used with ordinary electronic equipment or devices, Should you intend to use these products with equipment or devices which require an extremely high level of reliability and the malfunction of with would directly endanger human life (such as medical instruments, aerospace machinery, nuclear-reactor controllers, fuel controllers and other safety devices), please be sure to consult with our sales representative in advance.

Website: <http://www.prisemi.com>

For additional information, please contact your local Sales Representative.

©Copyright 2009, Prisemi Electronics

 **Prisemi**[®] is a registered trademark of Prisemi Electronics.

All rights are reserved.