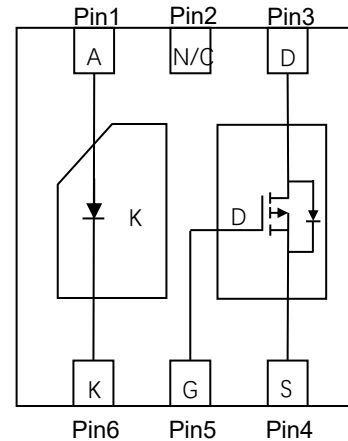

Description

MOSFET Product Summary		
$V_{DS}(V)$	$R_{DS(on)}(\Omega)$	$I_D(A)$
-20	0.110 @ $V_{GS}=-4.5V$	-2.8
	0.160 @ $V_{GS}=-2.5V$	-2.0
	0.240 @ $V_{GS}=-1.8V$	-1.8

Schottky Product Summary		
$V_{KA}(V)$	$V_F(V)$	$I_F(A)$
20	0.48V @ 0.5A	1.0

Electrical characteristics per line@25°C (unless otherwise specified)

Parameter		Symbol	Value	Units
Drain-Source Voltage (MOSFET and Schottky)		V_{DS}	-20	V
Reverse Voltage (Schottky)		V_{KA}	20	
Gate-Source Voltage (MOSFET)		V_{GS}	± 10	
Continuous Drain Current ($T_J=150^\circ C$) (MOSFET)	$T_A=25^\circ C$	I_D	-2.8	A
	$T_A=85^\circ C$		-1.9	
Pulsed Drain Current (MOSFET)		I_{DM}	-10	
Continuous Source Current (MOSFET Diode Conduction)		I_S	-0.9	
Average Forward Current (Schottky)		I_F	1.0	
Pulsed Forward Current (Schottky)		I_{FM}	7	
Maximum Power Dissipation (MOSFET)	$T_A=25^\circ C$	P_D	1.1	
	$T_A=85^\circ C$		0.6	
Maximum Power Dissipation (Schottky)	$T_A=25^\circ C$		0.96	
	$T_A=85^\circ C$		0.59	
Operating Junction and Storage Temperature Range		T_J, T_{stg}	-55 ~ 150	$^\circ C$
Soldering Recommendation (Peak Temperature)		T_{PS}	260	$^\circ C$

Absolute maximum ratings@25°C

Parameter		Condition	Symbol	Typical	Maximum	Unit
Thermal Resistance (Junction to Ambient)	MOSFET	$t \leq 5\text{sec}$	R_{thJA}	50	60	°C/W
	Schottky			77	95	
	MOSFET	Steady State		90	110	
	Schottky			110	130	
Thermal Resistance (Junction to Pin)	MOSFET	Steady State	R_{thJP}	30	40	
	Schottky			33	40	

MOSFET Specifications ($T_J=25^\circ\text{C}$ Unless Otherwise Noted)

Parameter	Symbol	Condition	Min	Typ	Max	Unit
Static						
Gate Threshold Voltage	$V_{GS(th)}$	$V_{DS}=V_{GS}, I_D=-250\mu\text{A}$	-0.45			V
Gate-Body Leakage Current	I_{GSS}	$V_{DS}=0\text{V}, V_{GS}=\pm 8\text{V}$			± 100	nA
Zero Gate Voltage Drain Current	I_{DSS}	$V_{DS}=-16\text{V}, V_{GS}=0\text{V}$			-1	μA
		$V_{DS}=-16\text{V}, V_{GS}=0\text{V}, T_J=85^\circ\text{C}$			-5	
On-State Drain Current	$I_D(on)$	$V_{DS}\leq -5\text{V}, V_{GS}=-4.5\text{V}$	-2			A
Drain-Source On-State Resistance	$R_{DS(on)}$	$V_{GS}=-4.5\text{V}, I_D=-2.8\text{A}$		0.095	0.110	Ω
		$V_{GS}=-2.5\text{V}, I_D=-2.0\text{A}$		0.140	0.160	
		$V_{GS}=-1.8\text{V}, I_D=-1.8\text{A}$		0.200	0.240	
Forward Tran Conductance	g_{fs}	$V_{DS}=-10\text{V}, I_D=-2.8\text{A}$		7		S
Diode Forward Voltage	V_{SD}	$I_S=-0.9\text{A}, V_{GS}=0\text{V}$		-0.8	-1.2	V
Dynamic						
Total Gate Charge	Q_g	$V_{DS}=-10\text{V}$ $V_{GS}=-4.5\text{V}$ $I_D=-2.8\text{A}$		4.2	6.0	nC
Gate-Source Charge	Q_{gs}			1.3		
Gate-Drain Charge	Q_{gd}			0.60		
Turn-On Delay Time	$t_{d(on)}$	$V_{DD}=-10\text{V}, R_L=10\Omega$ $I_D=-1\text{A}$ $V_{GEN}=-4.5\text{V}, R_G=6\Omega$		15	23	ns
Rise Time	t_r			28	42	
Turn-Off Delay Time	$t_{d(off)}$			28	42	
Fall Time	t_f			25	38	
Source-Drain Reverse Recovery Time	t_{rr}	$I_F=-0.9\text{A}, di/dt=100\text{A}/\mu\text{s}$		20	40	

Schottky Specifications ($T_J=25^\circ\text{C}$ Unless Otherwise Noted)

Parameter	Symbol	Condition	Min	Typ	Max	Unit
Forward Voltage	V_F	$I_F=0.5\text{A}$		0.43	0.48	V
		$I_F=0.5\text{A}, T_J=125^\circ\text{C}$		0.33	0.4	
Maximum Reverse Leakage Current	I_{rm}	$V_r=20\text{V}$		0.002	0.100	mA
		$V_r=20\text{V}, T_J=85^\circ\text{C}$		0.10	1	
		$V_r=20\text{V}, T_J=125^\circ\text{C}$		1.5	10	
Junction Capacitance	C_T	$V_r=10\text{V}$		31		pF

Typical Characteristics

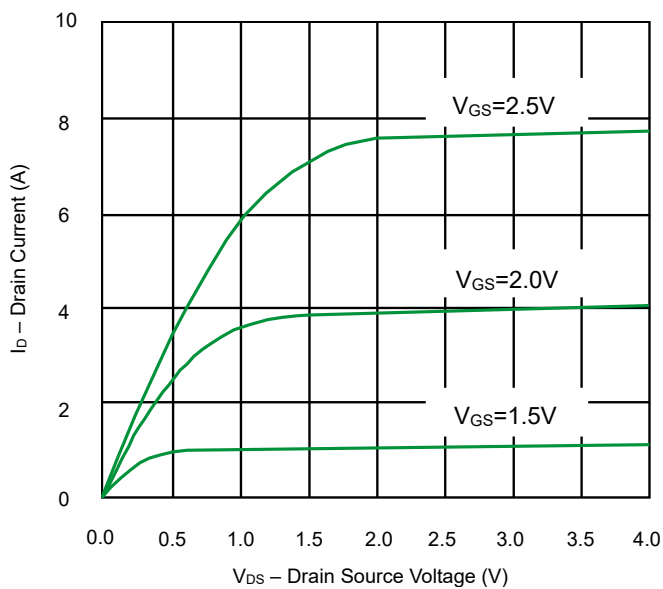

Fig 1. Output Characteristics

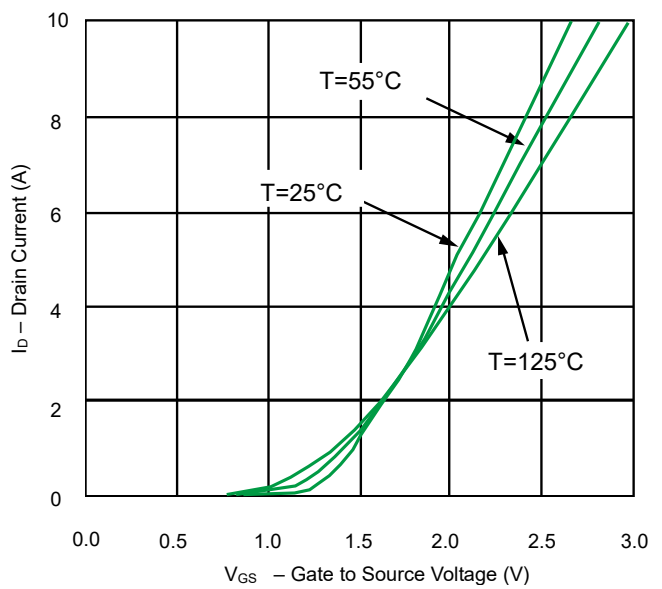

Fig 2. Transfer Characteristics

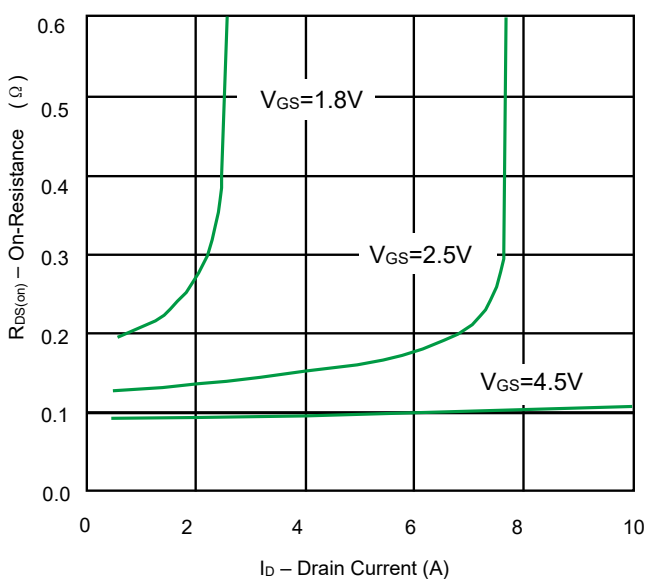

Fig 3. On-Resistance vs. Drain Current

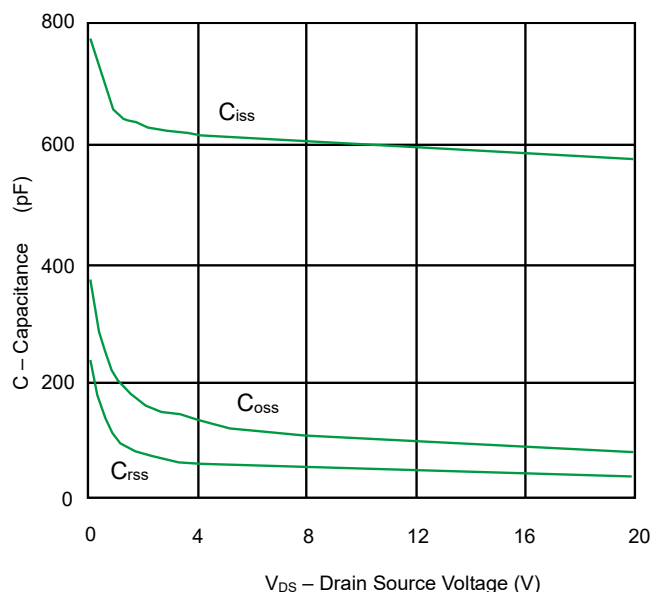
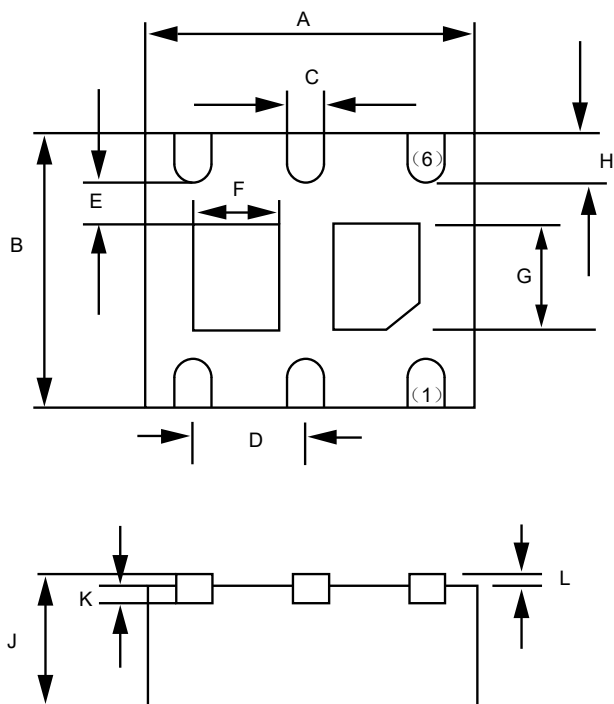
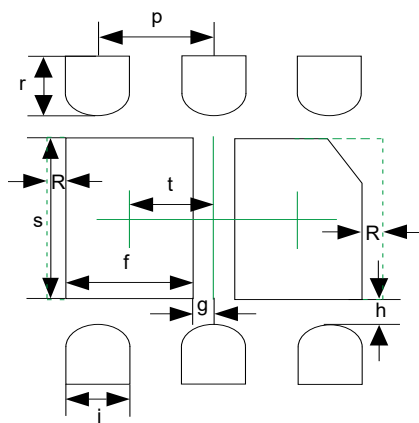

Fig 4. Capacitance

Product dimension DFN-6L(2*2)



Dim	Millimeters		Inches	
	MIN	MAX	MIN	MAX
A	1.924	2.076	0.076	0.082
B	1.924	2.076	0.076	0.082
C	0.250	0.350	0.010	0.014
D	0.650 (typ.)		0.026 (typ.)	
E	0.200 MIN.		0.008 MIN.	
F	0.520	0.720	0.020	0.028
G	0.900	1.100	0.035	0.043
H	0.174	0.326	0.007	0.013
J	0.550	0.650	0.021	0.027
K	0.206 REF		0.206 REF	
L	0.203 REF		0.203 REF	



If there is enough place in PCB. It can be mounted with copper along the dotted line in order to optimize thermal design.

Dim	Millimeters	
	MIN	MAX
p	0.60	0.70
r	0.40	0.50
s	1.05	1.15
t	0.42	0.52
f	0.67	0.77
g	0.06	0.16
h	0.1	0.2
j	0.35	0.45
R	0.1	0.2

Ordering information

Device	Package	Shipping
PPMS6N20V3	DFN-6L (2*2)	3000 / Tape & Reel

IMPORTANT NOTICE

 and **Prisemi**[®] are registered trademarks of **Prisemi Electronics Co., Ltd** (Prisemi). Prisemi reserves the right to make changes without further notice to any products herein. Prisemi makes no warranty, representation or guarantee regarding the suitability of its products for any particular purpose, nor does Prisemi assume any liability arising out of the application or use of any product or circuit, and specifically disclaims any and all liability, including without limitation special, consequential or incidental damages. "Typical" parameters which may be provided in Prisemi data sheets and/or specifications can and do vary in different applications and actual performance may vary over time. All operating parameters, including "Typicals" must be validated for each customer application by customer's technical experts. Prisemi does not convey any license under its patent rights nor the rights of others. The products listed in this document are designed to be used with ordinary electronic equipment or devices, Should you intend to use these products with equipment or devices which require an extremely high level of reliability and the malfunction of which would directly endanger human life (such as medical instruments, aerospace machinery, nuclear-reactor controllers, fuel controllers and other safety devices), please be sure to consult with our sales representative in advance.

Website: <http://www.prisemi.com>

For additional information, please contact your local Sales Representative.

©Copyright 2009, Prisemi Electronics

 **Prisemi**[®] is a registered trademark of Prisemi Electronics.

All rights are reserved.